

CLARK *ELECTRIC CLUTCH*

**AUTOMATIC TENSION CONTROL
FOR REELING APPLICATIONS**

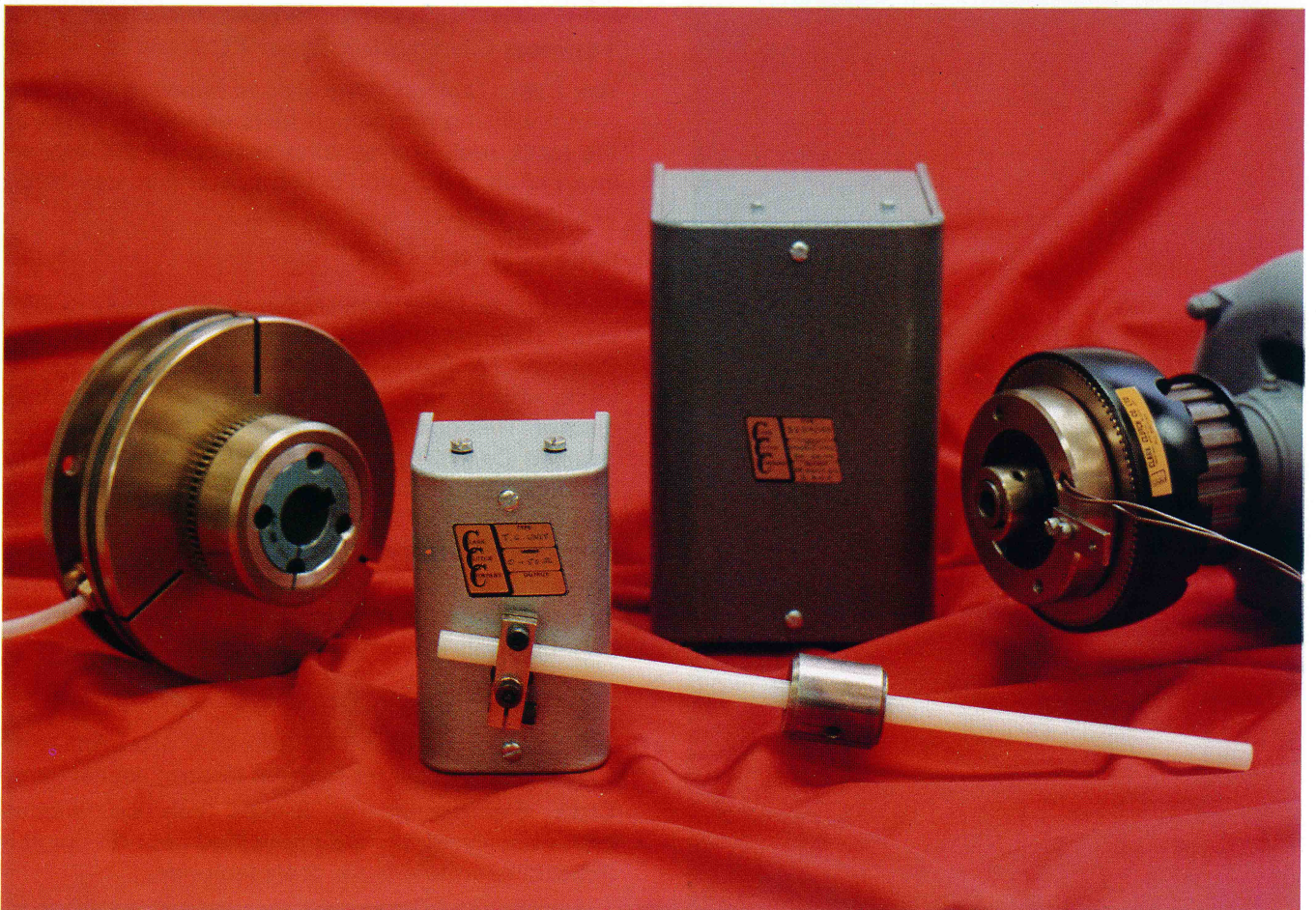
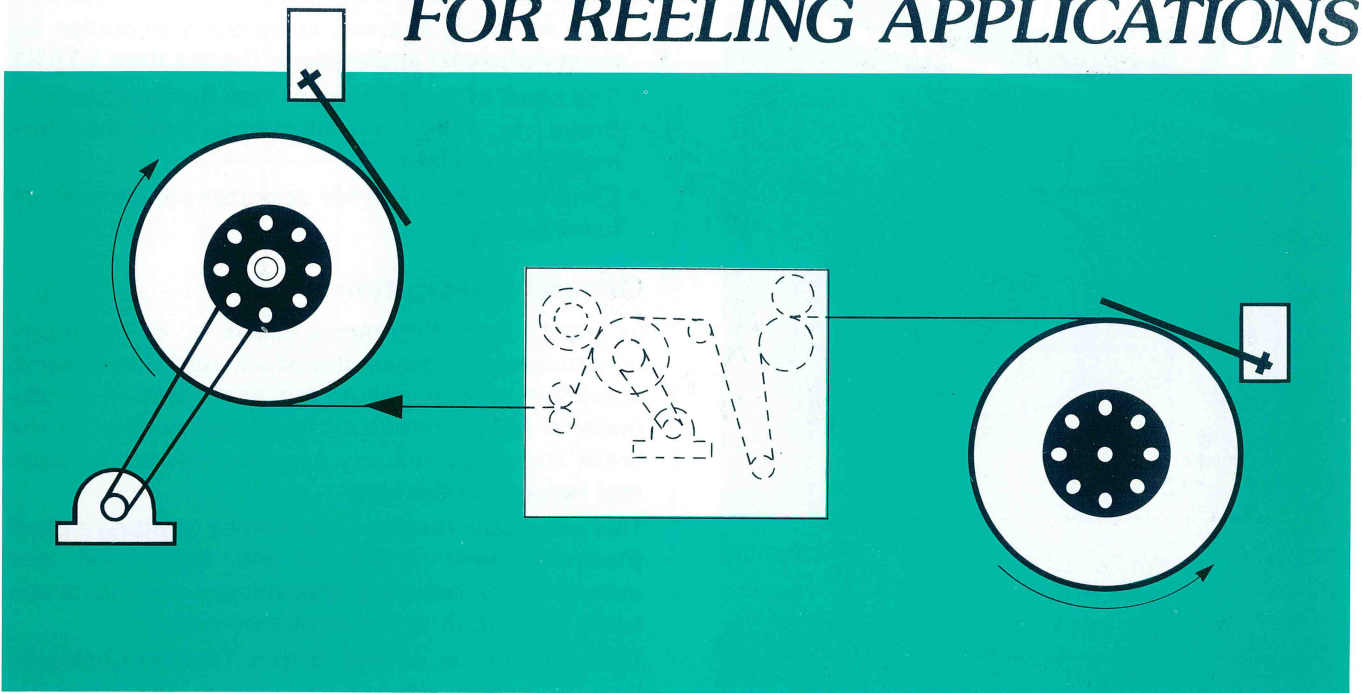

Automatic Tension Control for Stock Reel

UNWINDING

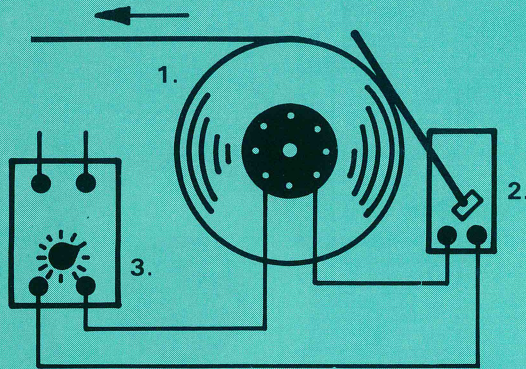

1. Brake on stock reel.
2. Tension controller.
3. Power unit with preset tension.

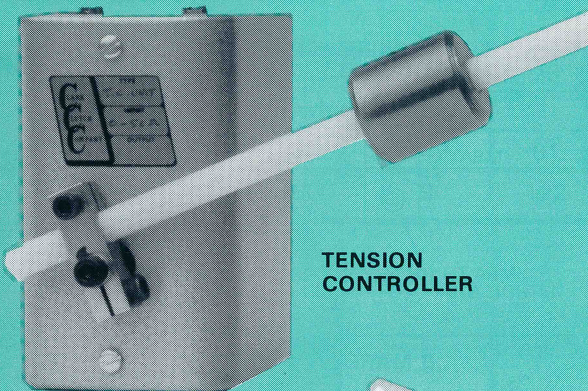

TENSION CONTROLLER

ELECTROMAGNETIC BRAKES 175-400

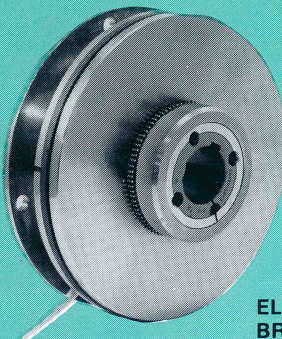
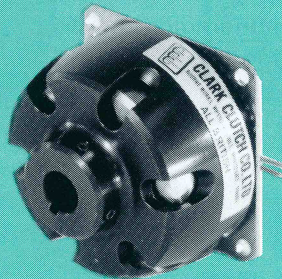

ELECTROMAGNETIC BRAKES (LT600 and LT800)

- Automatic Tension Control by means of a simple cost effective system, sufficiently accurate for most industrial applications (better than $\pm 15\%$).
- The heart of the system, a Clark Electromagnetic Brake is fully self-adjusting and therefore maintenance free.
- Eliminates the need for operator adjustment of hand brakes.

General Description

In most unwinding applications it is necessary continuously to brake the stock reel. For smooth operation and to ensure an even tension in the material being unreeled, the torque applied by the brake should be reduced progressively as the stock reel reduces in diameter.

This automatic function is achieved by fitting a Clark Electromagnetic Brake to the stock reel and automatically reducing the voltage applied to the brake in relation to the stock reel diameter.

This diameter is sensed with a Tension Controller type TC which reduces the voltage applied to the brake.

Tension Controller Type TC

The Clark Tension Controller is supplied complete with a sensing arm which rests on the periphery of the stock reel. The sensing arm pivots through an angle of up to 80° , and drives a potentiometer inside the Controller.

Power Unit

Clark Power Units convert the mains supply to 24v D.C. required by Electromagnetic Brakes and Clutches. For Tension Control applications the Power Units incorporate a manual tension presetting control. This control presets the level at which the Tension Control Unit maintains the tension, i.e. at minimum setting the tension is preset almost to zero, and can be set to different values to cater for various web widths and materials.

Alternatively this preset control can be supplied in a separate case for remote operation or uncased for panel mounting.

Electromagnetic Brakes

All Clark Brakes sizes 175, 250, 400 and LT600 and LT800 are suitable for Tension Control applications. Clark Electromagnetic Brakes can be slipped continuously within their specified heat dissipation limits chosen to ensure acceptable life.

Continuously Slipping Brake Control

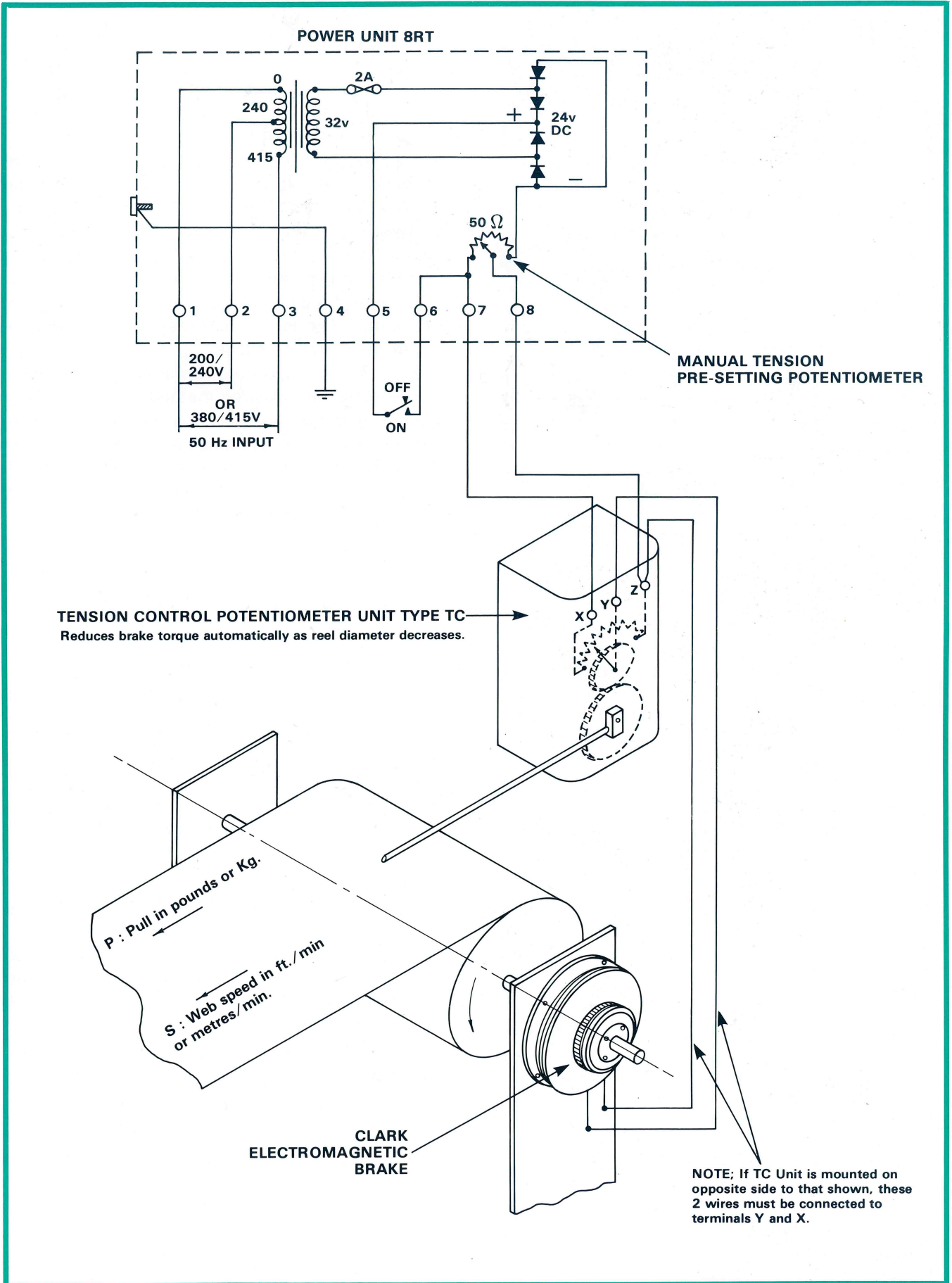

Automatic Tension Control for Take-Up Reel

WINDING

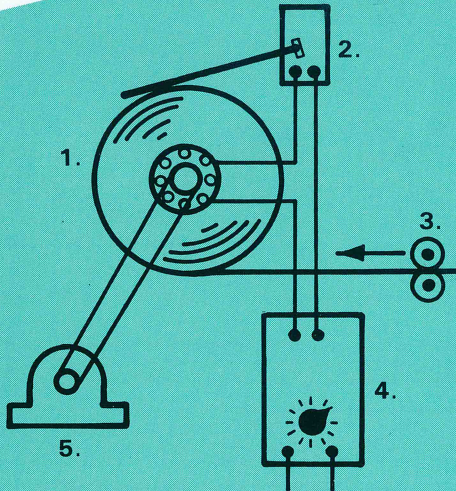

1. Take-up reel and clutch.
2. Tension controller.
3. Constant speed nip rollers.
4. Power unit with preset tension.
5. Constant speed winding motor.

General Description

In the majority of reel winding applications there are nip rollers or omega wraps in the process which are feeding the material through at a constant speed.

To ensure that the take-up reel is wound smoothly without wrinkling or overstretch of the material, it is essential to keep the tension reasonably constant.

This requires the torque applied to the take-up reel to be controlled so that it increases as the diameter of the take-up reel increases.

In the majority of applications this can most easily be achieved by the following method :

A motor speed and pulley ratio is chosen so that at the commencement of winding, the winding mandrel driven by the constant speed winding motor runs approximately 5% above the speed necessary to take up the material being fed by the nip rollers.

A Clark Clutch is used to transmit the drive from the motor to the take-up reel. The clutch is continuously slipping, the torque being automatically increased by the tension controller as the reel diameter increases.

Electromagnetic Clutch

The rugged construction of the Clark clutch makes it particularly suited for web tension control, within its heat dissipation limits.

It is often most convenient to have the clutch fitted with a pulley or chain wheel drive and fitted to an extension of the re-wind shaft. This is the clutch type BM-EH, and Data Sheets covering various sizes are available.

Combined Reel Unwinding and Winding

Frequently a process involves both unwinding of a stock reel and winding of a take-up reel. In this case two Tension Controllers, one brake, one clutch, and two power units are required for overall tension control.

Technical Information

On page 8 of this leaflet are given some typical web tensions for a range of materials. Also heat dissipation and torque values for clutches and brakes.

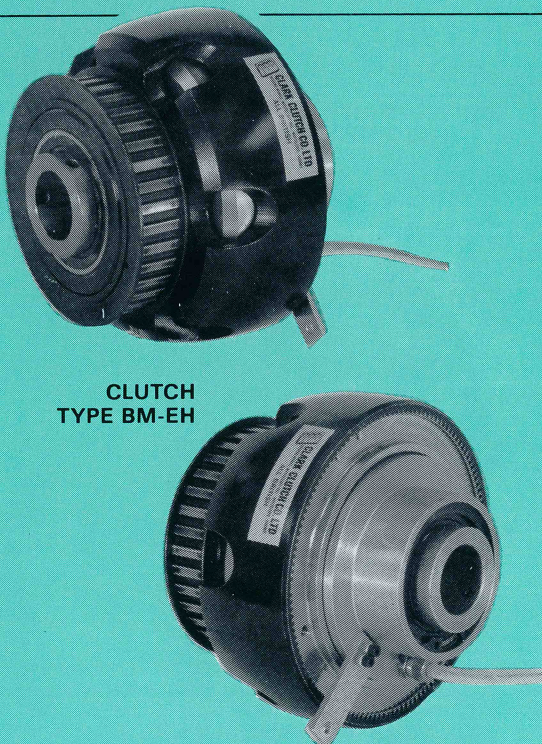

Continuously Slipping Clutch Control

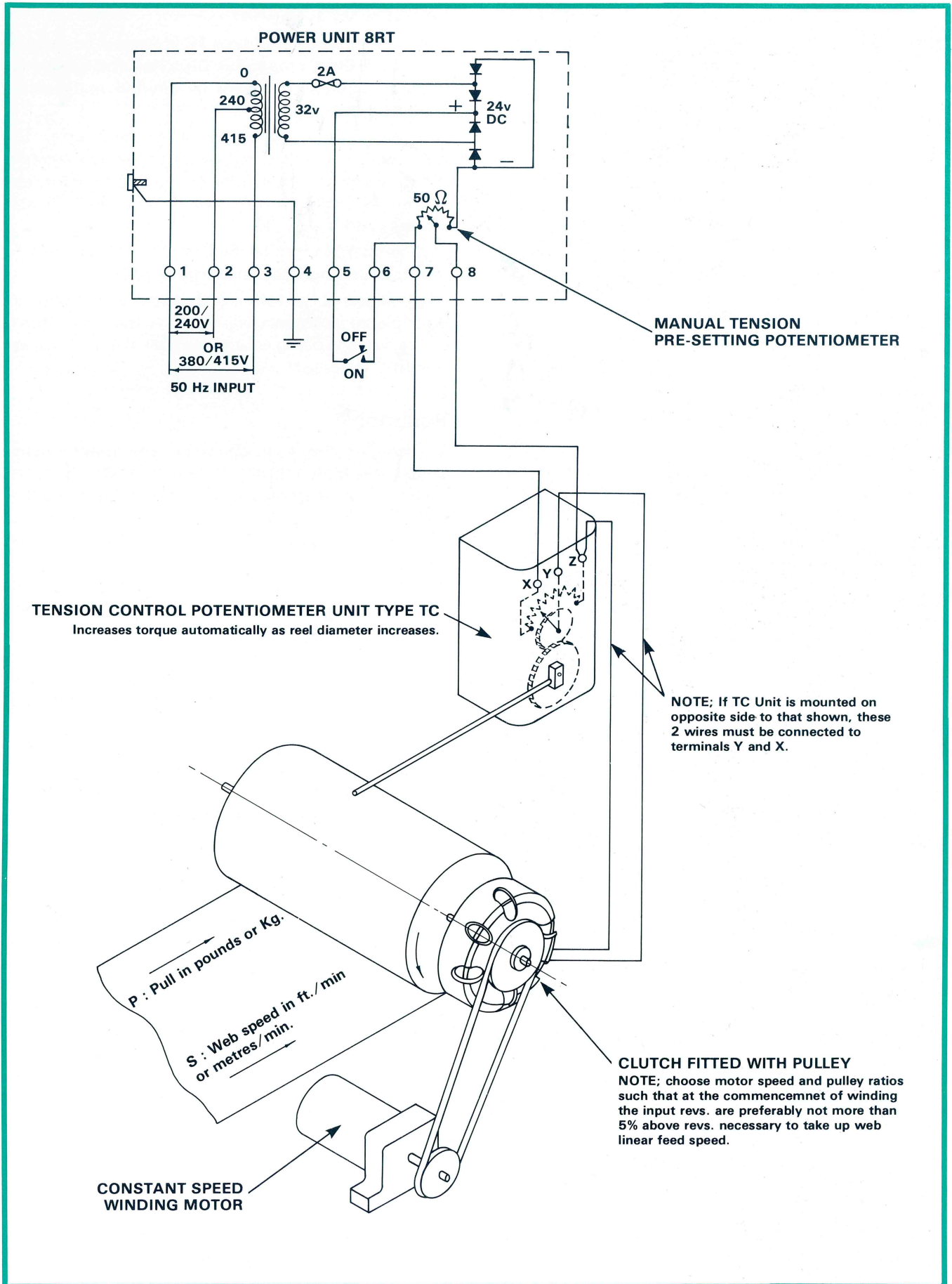

Tension Controller

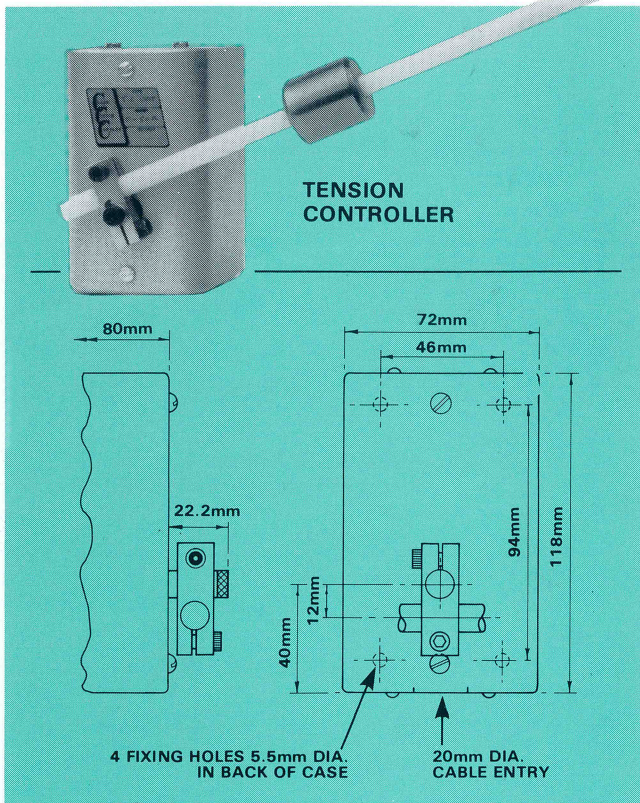

DIAGRAM A.

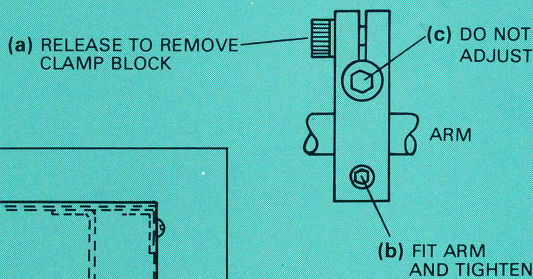

DIAGRAM B.

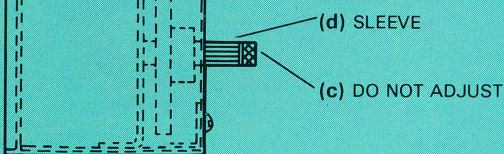
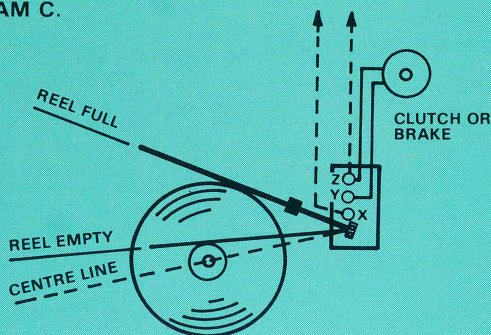

DIAGRAM C.



Installation Procedure

General Description

The Tension Controller type TC is used in conjunction with Clark Electromagnetic Clutches and Brakes for automatic tension control in unwind and reeling applications.

The TC Unit incorporates a sensing arm, the movement caused by following the increasing/decreasing reel diameter rotates a potentiometer. The maximum angle through which the sensing arm moves is 80°.

The standard length of the Delrin sensing arm is 12 inches, but longer arms can be supplied.

The position of the cylindrical weight on the arm can be adjusted by slackening a grub screw, the purpose of the weight being to ensure that the arm always remains in contact with the reel.

Function

To monitor the reel diameter and automatically adjust the clutch/brake torque to ensure that the web tension is constant throughout the wind/unwind process. This is necessary to prevent stretch in the web material ensuring that the reels are wound evenly.

In reeling applications, to keep the right tension, the torque applied to the reel must be increased progressively as the diameter increases.

In unreeling applications, the braking torque on the reel must be reduced progressively as the reel diameter decreases in order to keep the web tension constant.

Frequently a process involves both unwinding of a stock reel and winding of a take-up reel. In this case two Tension Controllers, one brake, one clutch and two power units are required for overall tension control.

Setting Up and Wiring Instructions

Where the reels are lifted vertically out of the machine, the TC arm may be mounted under the reel and spring loaded so that the arm bears on the periphery of the reel. In this manner the arm is automatically placed at the correct position as the empty reel is loaded into the machine. See Diagram E (opposite page).

Where the reels are loaded sideways onto the machine, provision has to be made to move the arm away to facilitate reel loading/unloading and then returned to operating position before the machine starts.

1. Ensure that the position of the TC Unit and the length of the sensing arm is such that the angular movement of the arm between the Reel Full and the Centre Line is not more than 80° (see diagrams C and D).

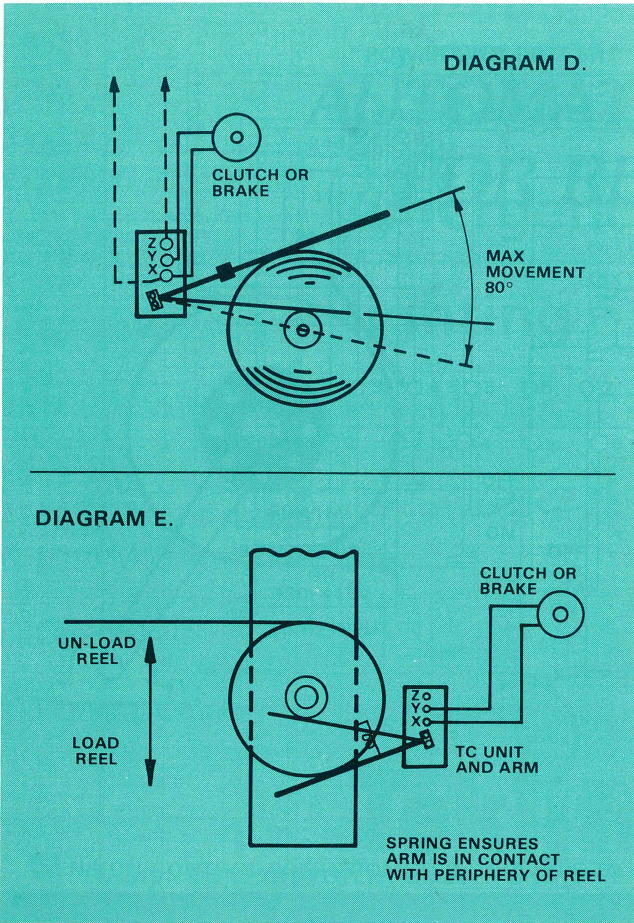

Ideally, the angular movement would be about 70° and preferably not less than 40°. Mount the TC Unit as near as possible to the reel to obtain maximum angle of movement.

2. Remove the clamp block (diagram A) by slackening screw (a) and drawing the block off the sleeve (d) in diagram B. Do not slacken screw (c).
3. Remove the lid which is retained by two fixing screws. Mount the TC Unit through fixing holes in the back of case.
4. Wire the terminal block, noting that the two wires for the clutch coil or brake coil connect to different terminals depending on the position of the TC Unit (See diagrams C and D). See complete wiring diagrams, pages 3 and 5, for other connections. Refit the cover.
5. **If mounted as Diagram C.**
Turn the sleeve (d) on diagram B fully anti-clockwise. Now fit the clamping block with the sensing arm over the sleeve so that the sleeve is fully anti-clockwise when the arm is in line with the centre of the reel. Now tighten screw (a).
6. **If mounted as Diagram D**
Turn the sleeve (d) on diagram B fully clockwise. Now fit the clamping block with the sensing arm over the sleeve so that the sleeve is fully clockwise when the arm is in line with the centre of the reel. Now tighten screw (a).

Calculations

Clutches and brakes for tension control applications are generally selected for consideration of their thermal rating rather than torque rating, since the clutches and brakes are slipping throughout the wind/unwind. The heat dissipation is calculated from the total web tension required, the linear speed of the web, and in the case of the clutches for winding, the minimum and maximum reel diameters.

Brake Heat Dissipation in Nm/Min

is calculated from $2 \pi NT$ where :

N is the slip speed in r.p.m.

T is the torque in Nm.

P is the required web tension in kg.

S is the linear speed of the web in metres/min.

D is the diameter of stock reel in metres.

Heat dissipation is constant for the brake throughout the unwind process.

$$N \text{ (slip speed)} = \frac{S}{\pi D \text{ (max.)}} \text{ r.p.m.}$$

$$\text{Torque } T = \frac{D \text{ max.} \times P \times 9.81}{2} \text{ Nm.}$$

$$\text{Brake heat dissipation} = 2 \pi NT \text{ Nm/min.}$$

Clutch Heat Dissipation in Nm/Min.

is calculated from $2 \pi NT$ where :

N the slip speed, is found by subtracting the r.p.m. of the reel at maximum diameter from the constant input r.p.m. at the clutch.

The input r.p.m. should be approximately 5% greater than that necessary to take up the web at minimum reel diameter.

Heat dissipation increases to its maximum at the greatest reel diameter.

Clutch torque **T** calculated as for brake.

$$\text{Clutch heat dissipation} = 2 \pi NT \text{ Nm/min.}$$

Clutch and brake heat dissipation may be calculated as above, and suitable clutches and brakes can be selected by consulting the data sheets in the catalogue where torque and heat dissipation ratings are listed.

Technical Information

Typical Web Tension

The actual web tension required depends on the material being handled as well as the particular characteristics of the process. However, the table gives some indication of winding web tension per unit width of some typical materials.

lbs per inch of web width	kg per cm of web width	Material
0.25	0.04	Plastic film. Tissue.
0.5	0.09	Newsprint.
1.0	0.18	Light craft. Medium paper.
2.0	0.36	Heavy craft paper.

Heat Dissipation and Torque

For tension control applications the maximum heat dissipation and maximum torque of clutches and brakes are shown in the tables.

Detailed technical data sheets on all sizes of Clark clutches and brakes are available.

Clutches

Size	Maximum heat dissipation		Maximum torque	
	ft.lb/min.	Nm./min.	lb.in	Nm.
175	640	870	10	1.1
250	970	1320	50	5.6
400	2050	2788	200	23
			lb.ft.	
600	10900	14820	45	61
800	14700	20000	90	122

Brakes

Size	Maximum heat dissipation		Maximum torque	
	ft.lb/min.	Nm./min.	lb.in.	Nm.
175	640	870	10	1.1
250	970	1320	50	5.6
400	2050	2788	200	23
			lb.ft.	
LT600	8700	11800	22	30
LT800	11700	15900	45	61

Technical Service

Our engineers would be pleased to recommend the correct size of brake and/or clutch on receipt of the following details :-

Clutch for take up reel :

- Web speed. ● Minimum diameter of take-up reel.
- Maximum diameter of take-up reel.
- Web tension per unit width.
- Web width. ● Type of material.

Brake for stock reel :

- Web tension per unit width. ● Width of web.
- Web speed. ● Maximum diameter of stock reel.
- Type of material.

