

CLARK *ELECTRIC CLUTCH* *POWER BRAKES*

DATA SHEET

**SIZE
PB600 BRAKE**



**Typical Torque/voltage Characteristic
PB600 Brake**

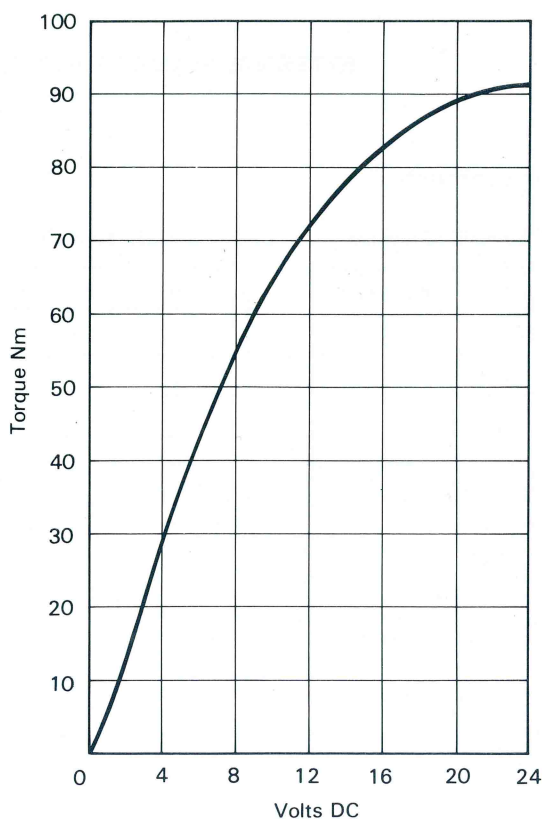

PB600 Power Brake

Rated Torque 70 Nm 52 lb ft.

Clark Power Brakes are residual free and provide control for machine shafts where it is desired to:

- Stop a shaft rapidly.
- Stop a shaft accurately.
- Stop a shaft gently.
- Hold a shaft locked against a load.
- Slip a shaft to provide tension.

Fixed Braking Torque

For applications where maximum braking torque is required the brake should be used with constant 24V DC output power unit type 8.

Variable Braking Torque

Used with Power Unit 8RT the brake torque may be pre-set at any point between maximum and minimum.

The torque/voltage curve on the left may be used as a guide to voltage setting. The brake torque obtained may vary up to $\pm 15^\circ$ from the applied voltage levels shown.

Assembly

The field is bolted to the machine frame and is available for internal or external fixing. The shaft can enter from either end of the brake or can pass right through it, thus giving the machine designer a convenient choice of shaft position.

Keyed taperbush assemblies are provided in the drive hub, making easy, positive fitting to the shaft and simple withdrawal. These taperbush assemblies are reversible so that 'lock up' or withdrawal can be from the most convenient end.

Operation of the Brake

The splined portion of the hub carries the brakeplate. When the brake is energised, the brakeplate is attracted to the field, and pulls up against the friction ring. The brake is completely self-adjusting since no throw-off spring is used and the brake plate automatically moves along the splines as the friction ring wears.

General Specification

Rated Static Torque	: 70 Nm (52lb ft)
Standard Voltage	: 24 Volts DC
Rated Continuous Current	: 1 Amp
Resistance (20°C)	: 24 Ohms
Other Voltages Available	: 6, 12, 50, 90 & 180 Volts.
Maximum Speed	: 4,750 RPM.
Maximum Heat Dissipation (slipping)	
Input Speed 0-500 r.p.m.	: 11,800 Nm/min (8,700ft lb/min)
1,000 r.p.m.	: 18,300 Nm/min (13,450ft lb/min)
1,500 r.p.m.	: 23,700 Nm/min (17,400ft lb/min)
3,000 r.p.m.	: 39,400 Nm/min (29,000ft lb/min)
Weight	: 3.6kg (8lb)

Torque: Slip characteristic

i.e. Gives torque at moment of engagement and as load is decelerated.

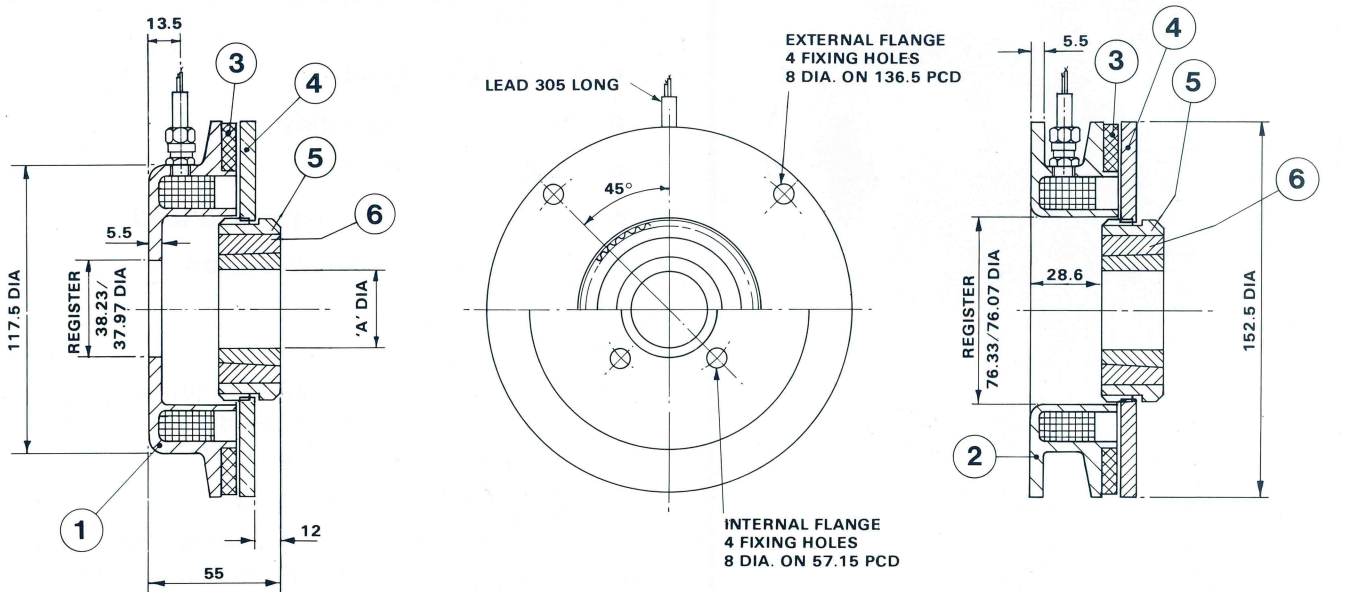
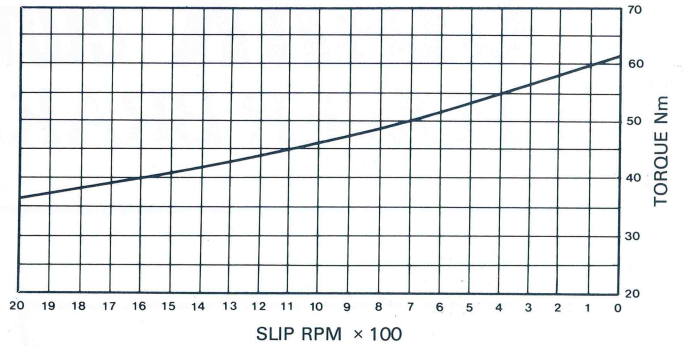

INTERNAL FLANGE MOUNTING

EXTERNAL FLANGE MOUNTING

The field spool registers should be used to ensure that the field spools are concentric with, and square to, the shaft passing through.

PARTS LIST

ITEM	PART No.	TITLE	No. OFF
1	658	FIELD INTERNAL FLANGE	1
2	659	FIELD EXTERNAL FLANGE	1
3	660	FRICTION RING	1
4	661	BRAKE PLATE	1
5	662	DRIVE HUB	1
6	663	TAPER BUSH ASSEMBLY	1

METRIC BORES

'A' DIA	KEYWAY
12	4 × 1.8
14 16	5 × 2.3
18 19	6 × 2.8
20 22	6 × 2.8
24 25	8 × 3.3
28 30	8 × 3.3
32	10 × 1.3

INCH BORES

'A' DIA. "	KEYWAY "
3/4	3/16 × 3/32
7/8	1/4 × 1/8
1	1/4 × 1/8
1 1/8	5/16 × 7/64
1 1/4	5/16 × 7/64

CLARK ELECTRIC CLUTCH AND CONTROLS Ltd

28 Victory Park, Trident Close, Medway City Estate, Rochester, Kent, ME2 4ER
 Tel.: +44 (0)1634 297408 Fax.: +44 (0)1634 739136 e-mail: sales@clarkelectric.co.uk