

ALL
BRITISH
COMPANY

SELF-ADJUSTING ELECTROMAGNETIC CLUTCHES

DATA
SHEET
SIZE
S600

MAXIMUM STATIC TORQUE 61 Nm. 45lb. ft.



FULLY SELF-ADJUSTING FOR WEAR

An important feature of this design makes regular maintenance unnecessary.

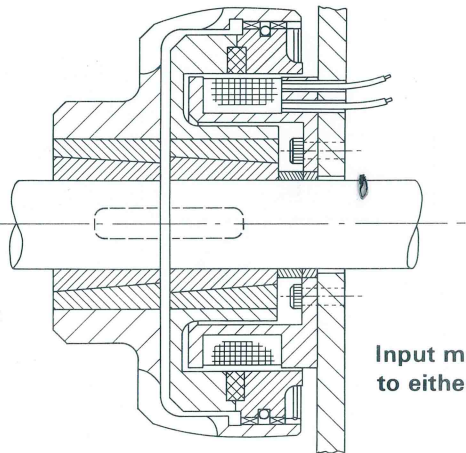

Input may be to either end

Clutch H.P. rating

R.P.M. at Clutch shaft	Allowing for shock torque loads up to 250% of steady load occurring.	
	When load is up to speed	During the accelerating period
	H.P.	H.P.
100	0.343	0.332
200	0.686	0.648
300	1.029	0.950
400	1.372	1.225
500	1.715	1.490
600	2.058	1.750
700	2.401	1.980
800	2.744	2.195
900	3.087	2.400
1000	3.430	2.620
1250	4.290	3.050
1440	4.940	3.350
2000	6.860	4.040
2500	8.575	4.380

General Specification

Maximum Static Torque : 61 Nm (45lb.ft.)
 Standard Voltage : 24 Volts D.C.
 Rated Continuous Current : 1 amp at 24 V
 Resistance (20°C) : 24 Ohms
 Other Voltages Available : 6, 12, 50, 90 & 180 Volts D.C.
 Maximum Speed : 4750 R.P.M.
 Maximum Heat Dissipation (Slipping)
 At various R.P.M.

500 r.p.m.: 14,820 Nm/min (10,900 ft.lb/min)
 1000 r.p.m.: 22,440 Nm/min (16,500 ft.lb/min)
 1500 r.p.m.: 28,560 Nm/min (21,000 ft.lb/min)
 3000 r.p.m.: 49,640 Nm/min (36,500 ft.lb/min)

Weight : 6 kg (13lbs)

Torque: Slip characteristic

i.e. Gives torque at moment of engagement and as load is accelerated.

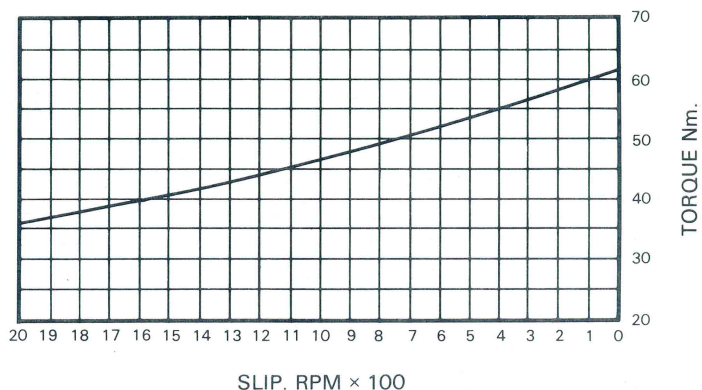

DATA SHEET
SIZE S600

SELF-ADJUSTING ELECTROMAGNETIC CLUTCHES

ALL BRITISH COMPANY

To design a satisfactory arrangement, reference should be made to the setting up procedure on the Installation & Maintenance sheet at the front of the catalogue.

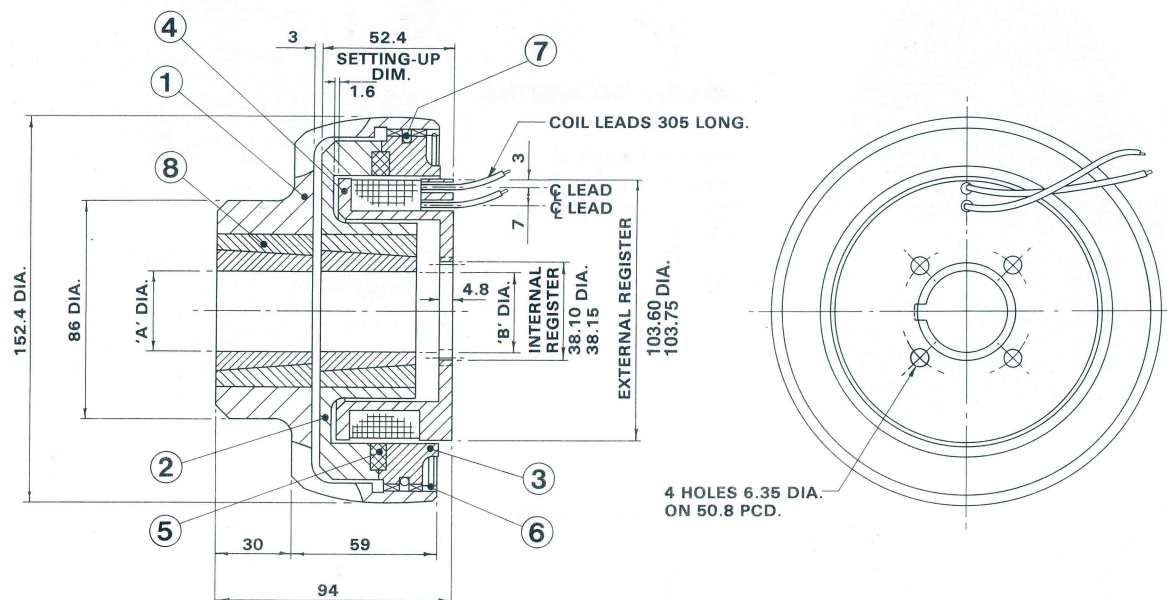

STANDARD BORES

'A' INCHES	'B' INCHES	KEYWAY WIDTH INCHES
3/4	3/4	3/16 × 3/32
7/8	7/8	1/4 × 1/8
1	1	1/4 × 1/8
1 1/8	1 1/8	5/16 × 7/64
1 1/4	1 1/4	5/16 × 7/64

PARTS LIST

ITEM	PART No.	TITLE	No. OFF
1	672	OUTER MEMBER	1
2	4860	INNER ROTOR	1
3	4139	DRIVE RING	1
4	675/1	FIELD SPOOL	1
5	4331	FRICTION RING	1
6	731	SPRING CLIP	1
7	732	CUSHION RING	1
8	B677	TAPER BUSH ASSY.	2

METRIC SIZES (mm)		
12	12	4 × 1.8
14	16	5 × 2.3
18	19	6 × 2.8
20	22	8 × 3.3
24	25	8 × 3.3
28	30	8 × 3.3
32	32	10 × 1.3

CLARK ELECTRIC CLUTCH AND CONTROLS Ltd

28 Victory Park, Trident Close, Medway City Estate, Rochester, Kent, ME2 4ER
Tel.: +44 (0)1634 297408 Fax.: +44 (0)1634 739136 e-mail: sales@clarkelectric.co.uk