

ALL
BRITISH
COMPANY

SELF-ADJUSTING ELECTROMAGNETIC CLUTCHES TYPE BM

DATA
SHEET
SIZE
BM250

WITH BEARING MOUNTED STATIONARY FIELD

MAXIMUM STATIC TORQUE 5.6 Nm 50lb.ins.

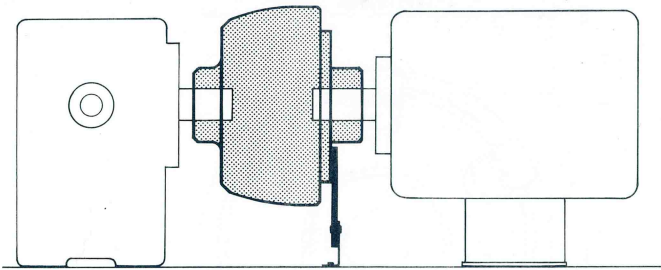

Two part assembly : Input may be from either end.



Clutch H.P. rating

R.P.M. at Clutch Shaft	Allowing for shock torque loads up to 250% of steady load occurring.	
	When load is up to speed	During the accelerating period
	H.P.	H.P.
100	0.032	0.028
200	0.064	0.053
300	0.096	0.076
400	0.128	0.099
500	0.160	0.121
600	0.192	0.140
700	0.224	0.160
800	0.256	0.178
900	0.288	0.197
1000	0.320	0.216
1250	0.40	0.254
1440	0.46	0.292
2000	0.64	0.406
2500	0.80	0.508

General Specification

Maximum Static Torque : 5.6 Nm. (50lb. ins.)
 Standard Voltage : 24 Volts D.C.
 Rated Continuous Current : 0.38 amp.
 Resistance (20°C) : 64 Ohms
 Other Voltages Available : 6, 12, 50, 90 Volts D.C.
 Maximum Speed : 5,000 R.P.M.
 Maximum Heat
 Dissipation (Slipping)

At various R.P.M.

0-500 r.p.m.: 1320 Nm/min (970 ft.lb/min)
 1000 r.p.m.: 2006 Nm/min (1475 ft.lb/min)
 1500 r.p.m.: 2455 Nm/min (1805 ft.lb/min)
 3000 r.p.m.: 3074 Nm/min (2260 ft.lb/min)

Weight : 0.62kg (1lb 6oz)

Torque: Slip characteristic

i.e. Gives torque at moment of engagement
 and as load is accelerated.

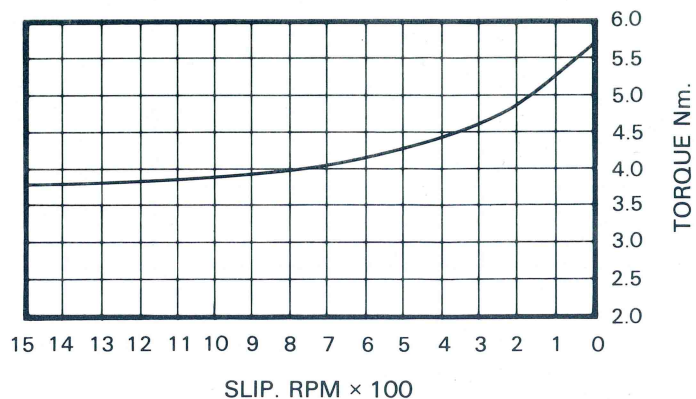

DATA SHEET
SIZE
BM250

SELF-ADJUSTING
ELECTROMAGNETIC
CLUTCHES
TYPE BM

ALL
BRITISH
COMPANY

WITH BEARING MOUNTED STATIONARY FIELD

Observe shaft parallel alignment requirements as given on Assembly and Maintenance data sheet at front of catalogue.

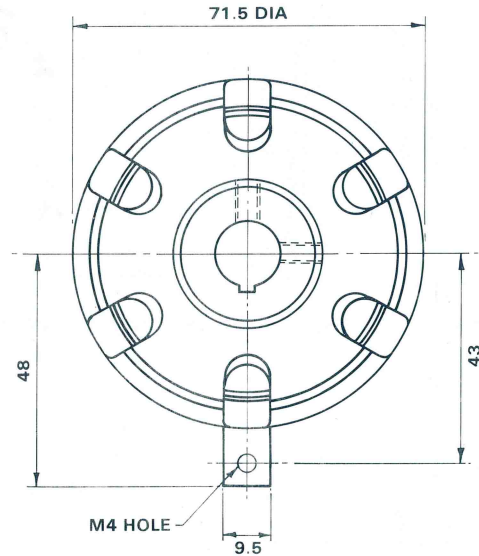
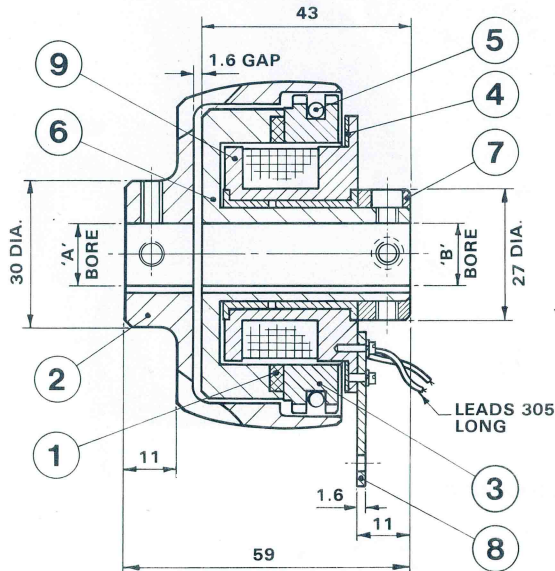

Note : Torque arm to be fastened only to relieve coil leads from light bearing drag. Do not tighten so as to load the bearing unnecessarily.

PARTS LIST

ITEM	PART No.	TITLE	No. OFF
1	5188	FRICTION RING	1
2	490	OUTER MEMBER	1
3	4682	DRIVE RING	1
4	566	MAGNETIC INSULATOR	1
5	734	CUSHION RING	1
6	2055	BM. INNER ROTOR	1
7	2056	BM. COLLAR	1
8	2057	BM. TORQUE ARM	1
9	2075	BM. FIELD SPOOL	1

STANDARD BORES

'A' INCHES	'B' INCHES	KEYWAY WIDTH INCHES
.3125/.3135	.3125/.3125	1/8
.375/.376	.375/.376	1/8
.4375/.4385	.4375/.4385	1/8
.500/.501	.500/.501	1/8
.625/.626	-	3/16
.750/.751	-	3/16
mm -0 +0.3	mm -0 +0.3	mm
8	8	2
9	9	3
10	10	3
11	11	4
12	12	4
14	14	5

CLARK ELECTRIC CLUTCH AND CONTROLS Ltd

28 Victory Park, Trident Close, Medway City Estate, Rochester, Kent, ME2 4ER
Tel.: +44 (0)1634 297408 Fax.: +44 (0)1634 739136 e-mail: sales@clarkelectric.co.uk