

ALL
BRITISH
COMPANY

SELF-ADJUSTING ELECTROMAGNETIC CLUTCHES TYPE BM

DATA
SHEET
SIZE
BM400

WITH BEARING MOUNTED STATIONARY FIELD

MAXIMUM STATIC TORQUE 23 N.m. 200lb.ins.

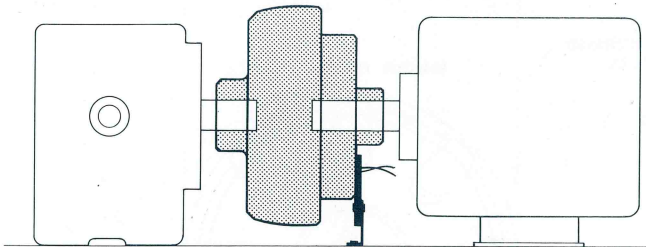

Two part assembly : Input may be from either end.

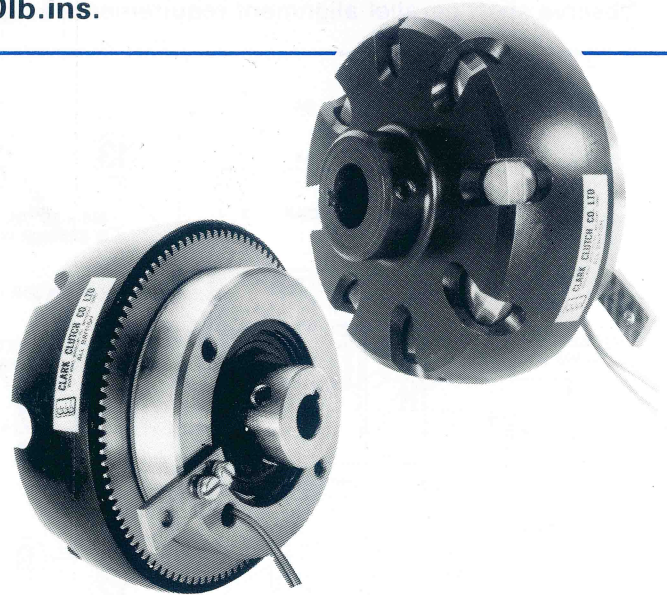

Clutch H.P. rating

R.P.M. at Clutch Shaft	Allowing for shock torque loads up to 250% of steady load occurring.	
	When load is up to speed	During the accelerating period
	H.P.	H.P.
100	0.128	0.12
200	0.256	0.228
300	0.384	0.33
400	0.512	0.424
500	0.640	0.515
600	0.768	0.6
700	0.896	0.686
800	1.024	0.768
900	1.152	0.854
1000	1.28	0.93
1250	1.6	1.125
1440	1.84	1.25
2000	2.56	1.78
2500	3.18	2.21

General Specification

Maximum Static Torque : 23 N.m. (200lb. ins.)
 Standard Voltage : 24 Volts D.C.
 Rated Continuous Current : 0.70 amp.
 Resistance (20°C) : 34 Ohms
 Other Voltages Available : 6, 12, 50, 90 Volts D.C.
 Maximum Speed : 6,250 R.P.M.
 Maximum Heat
 Dissipation (Slipping)

At various R.P.M. 500 r.p.m.: 2790 Nm/min (2050 ft.lb/min)
 1000 r.p.m.: 4250 Nm/min (3125 ft.lb/min)
 1500 r.p.m.: 5508 Nm/min (4050 ft.lb/min)
 3000 r.p.m.: 7923 Nm/min (5826 ft.lb/min)

Weight : 2.5kg (5½lb)

Torque: Slip characteristic

i.e. Gives torque at moment of engagement
and as load is accelerated.

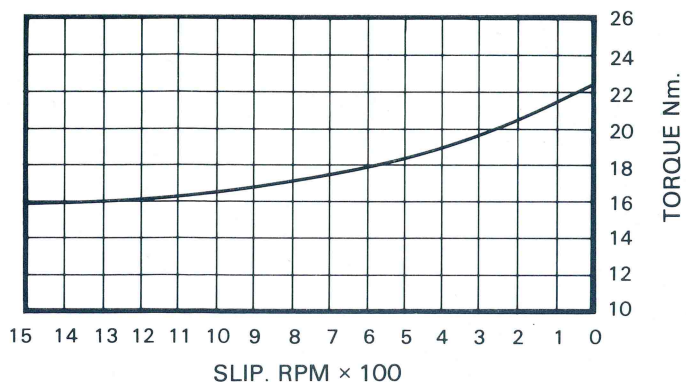

DATA SHEET
SIZE BM400

SELF-ADJUSTING ELECTROMAGNETIC CLUTCHES TYPE BM

ALL BRITISH COMPANY

WITH BEARING MOUNTED STATIONARY FIELD

Observe shaft parallel alignment requirements as given on installation data sheet at front of catalogue.

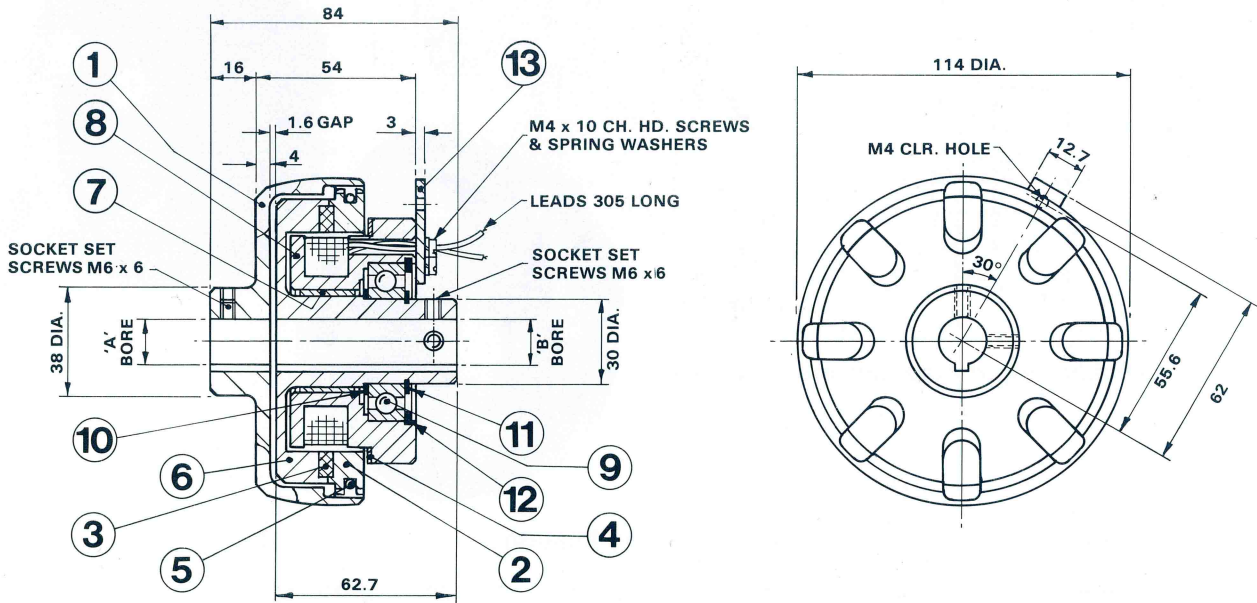

Note : Torque arm to be fastened only to relieve coil leads from light bearing drag. Do not tighten so as to load the bearing unnecessarily.

STANDARD BORES

PARTS LIST

ITEM	PART No.	TITLE	No. OFF
1	526	OUTER MEMBER/BORE	
2	4073	DRIVE RING	
3	4086	FRICTION RING	
4	565	MAGNETIC INSULATOR	
5	733	CUSHION RING	
6	4786	BM. INNER ROTOR/BORE	
7	2081	SLEEVE BEARING	
8	4592	BM. FIELD SPOOL ASSY.	
9		BALL BEARING 6006 2 RS	
10		ABUTMENT CIRCLIP (External) 30 mm.	
11		CIRCLIP (External) 30 mm.	
12		CIRCLIP (Internal) 55 mm.	
13	3157	TORQUE ARM	

'A' INCHES	'B' INCHES	KEYWAY WIDTH INCHES
.501/.500	.501/.500	1/8
.626/.625	.626/.625	3/16
.751/.750	.751/.750	3/16
.876/.876	-	1/4
1.001/1.000	-	1/4
mm ⁻⁰ / _{+0.018}	mm ⁻⁰ / _{+0.018}	mm
11	11	4
12	12	4
14	14	5
15	15	5
16	16	5
17	17	5
mm ⁻⁰ / _{+0.021}	mm ⁻⁰ / _{+0.021}	mm
19	19	6
20	20	6

CLARK ELECTRIC CLUTCH AND CONTROLS Ltd

28 Victory Park, Trident Close, Medway City Estate, Rochester, Kent, ME2 4ER
Tel.: +44 (0)1634 297408 Fax.: +44 (0)1634 739136 e-mail: sales@clarkelectric.co.uk