

ALL
BRITISH
COMPANY

EXTENDED-HUB & MOTOR MOUNTED ELECTROMAGNETIC CLUTCHES

FOR PULLEY, CHAINWHEEL,
SPUR GEAR OR FLEXIBLE COUPLING

DATA
SHEET
SIZE
BM600EH

MAXIMUM STATIC TORQUE 61 Nm. (45 lb. ft.)

Will transmit available torque of 3.7 Kw motor at 1440 r.p.m. with 2.5 times overload factor.

EXTENDED HUB CLUTCHES

Advantages

- Through shaft mounting - no shaft aligning required.
- Clark Clutches are self-adjusting throughout their life.
- No machining and fitting - the clutch is supplied complete with pulley etc.
- Will operate up to 60 times a minute where load inertia permits.
- Soft start facility available where used with Clark Silkstart Acceleration Controller.
- Low power device 1 amp at 24 volt.

These clutches are supplied with specified pulley or chainwheel etc., already fitted with the assembly, bored and keywayed as required.

Extended Hub Clutches are designed to provide an alternative method of automatic transmission where it is required to drive to or from a shaft via a clutch and pulley etc.

Since the assembly is carried on a through shaft, no other form of fixing is required other than a restraint for the torque arm.

The assembly consists of 3 sections each provided with internal spacers, the 3 sections are butted together on the shaft and the screws tightened in the collars.

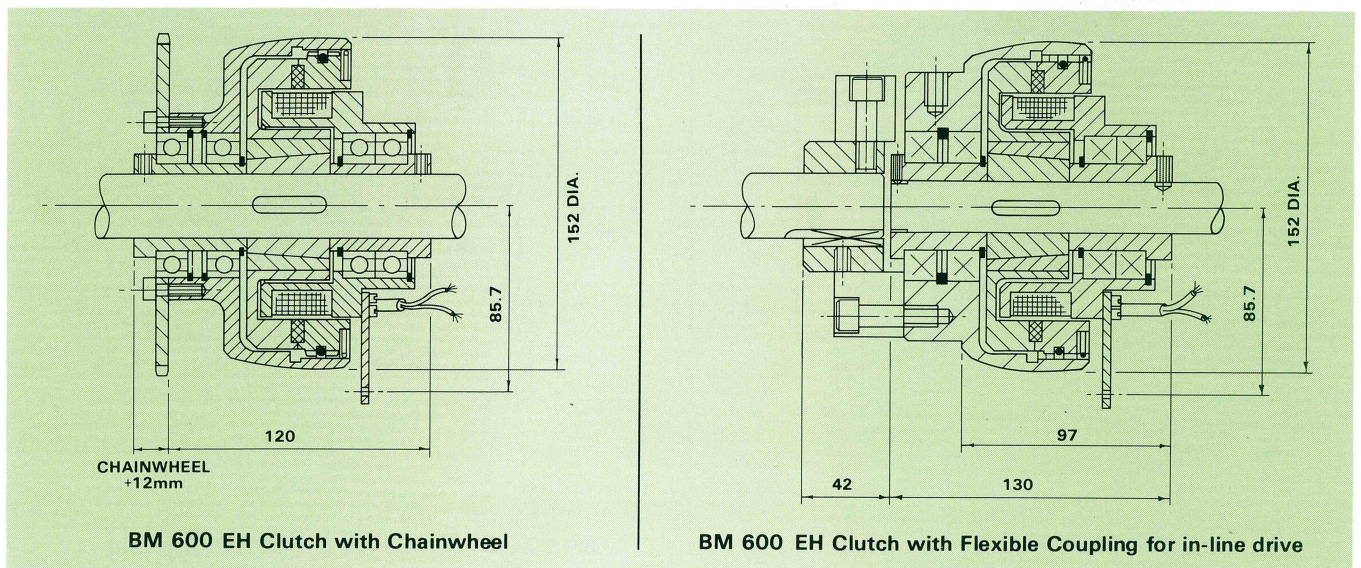
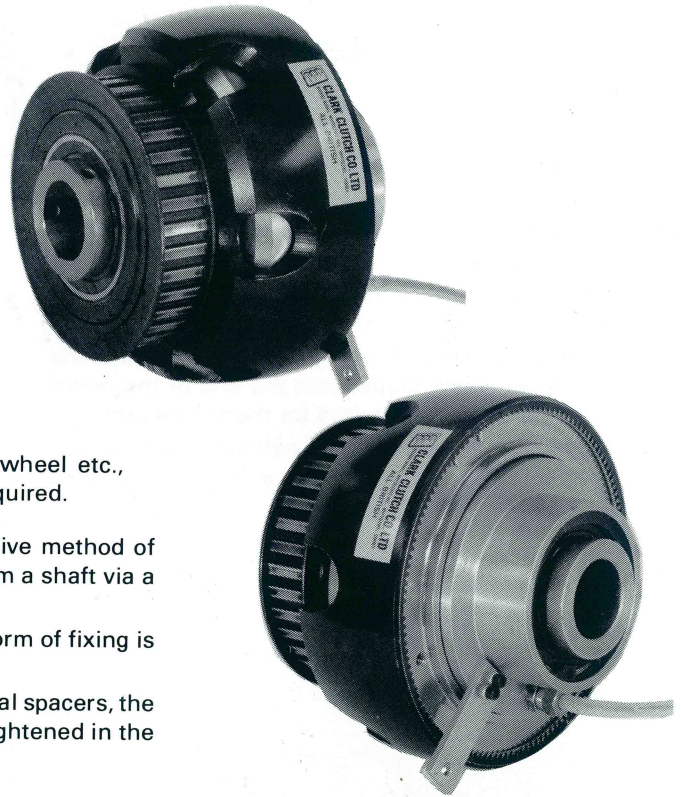

BM 600 EH Clutch with Chainwheel

BM 600 EH Clutch with Flexible Coupling for in-line drive

See BM600 Data Sheet for full technical details.

Bedding In

Where it is known that the Clutch and Brake are to be used on low speed applications, the unit may be supplied bedded-in in order that full torque will be available after a few operations.

On fast speed applications, the units will develop full torque after a few operations.

DATA
SHEET
SIZE
BM600EH

**EXTENDED-HUB
& MOTOR MOUNTED
ELECTROMAGNETIC
CLUTCHES**
FOR PULLEY, CHAINWHEEL,
SPUR GEAR OR FLEXIBLE COUPLING

ALL
BRITISH
COMPANY

MAXIMUM STATIC TORQUE 61 Nm. (45 lb. ft.)

Will transmit available torque of 3.7 Kw motor at 1440 r.p.m. with 2.5 times overload factor.

MOTOR MOUNTED PULLEY CLUTCHES

Advantages

- One piece assembly direct to motor shaft.

These clutches are custom built to provide a remotely controlled automatic drive from the shaft of a motor or gearbox.

The assembly comprises a specified pulley or chainwheel etc, fitted to the clutch, bored and keywayed as required.

The assembly is fitted as a single unit and secured to the shaft with a set screw tapped into the end of the motor shaft. A restraint is also required for the torque arm.

The unit may be removed from the shaft by a jacking screw, the assembly being provided with a suitably threaded portion.

The arrangement has several advantages :

- It avoids the need to erect and support a motor shaft extension to accommodate the Clutch.
- The pulley etc. is positioned to be over the motor bearings so the motor shaft and bearings are not overloaded.
- All Clark Clutches are self-adjusting for wear throughout their life.
- Soft start facility available where used with Clark Silkstart Acceleration Controller.

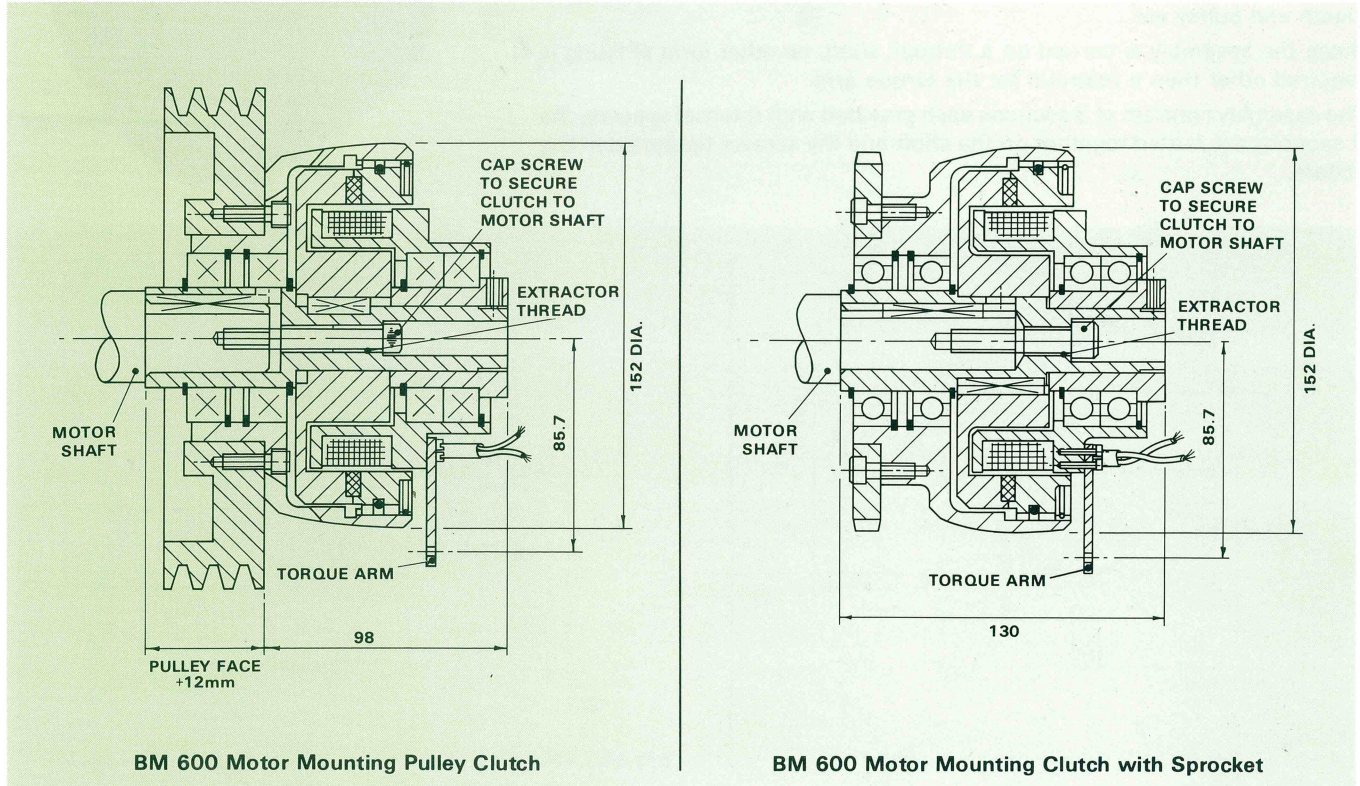

Electrical Note

If not using a Clark Power Unit, always connect a 0.22 mfd 1000v. capacitor permanently across the clutch or brake coil to protect the control switch contacts.

CLARK ELECTRIC CLUTCH AND CONTROLS Ltd
28 Victory Park, Trident Close, Medway City Estate, Rochester, Kent, ME2 4ER
Tel.: +44 (0)1634 297408 Fax.: +44 (0)1634 739136 e-mail: sales@clarkelectric.co.uk