

ALL
BRITISH
COMPANY

SELF-ADJUSTING ELECTROMAGNETIC CLUTCHES TYPE BM

DATA
SHEET
SIZE
BM800

WITH BEARING MOUNTED STATIONARY FIELD

MAXIMUM STATIC TORQUE 122 Nm. 90lb.ft.

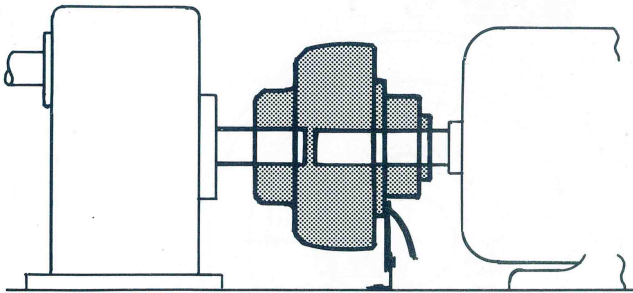

Two part assembly : Input may be from either end.

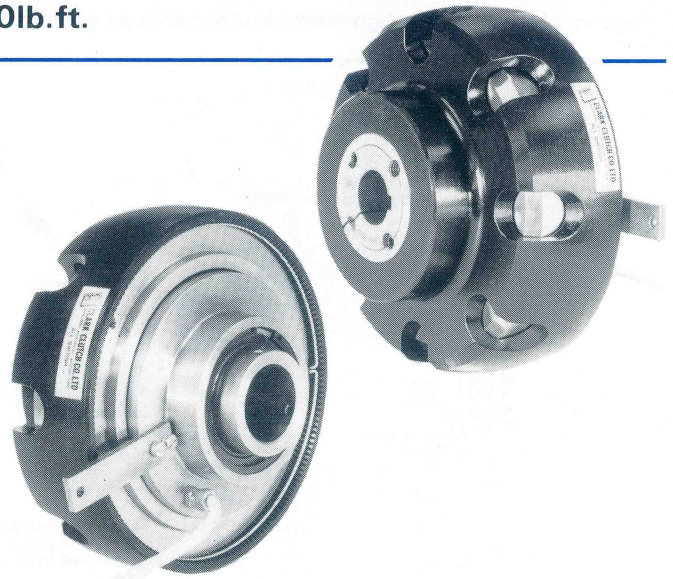

Clutch H.P. rating

R.P.M. at Clutch Shaft	Allowing for shock torque loads up to 250% of steady load occurring.	
	When load is up to speed	During the accelerating period
	H.P.	H.P.
100	0.686	0.658
200	1.372	1.250
300	2.058	1.810
400	2.744	2.280
500	3.430	2.750
600	4.116	3.160
700	4.802	3.470
800	5.488	3.800
900	6.174	4.060
1000	6.860	4.280
1250	8.575	4.680
1440	9.880	4.840
2000	13.720	5.040
2500	17.150	5.050

General Specification

Maximum Static Torque	: 122 Nm. (90lb. ft.)
Standard Voltage	: 24 Volts D.C.
Rated Continuous Current	: 1.3 amp.
Resistance (20°C)	: 17.8 Ohms
Other Voltages Available	: 6, 12, 50, 90 & 180 Volts D.C.
Maximum Speed	: 3600 r.p.m.
Maximum Heat Dissipation (Slipping)	
At various r.p.m.	
500 r.p.m.:	20,000 Nm/min (14,700 ft.lb/min)
1000 r.p.m.:	30,600 Nm/min (22,500 ft.lb/min)
1500 r.p.m.:	41,100 Nm/min (30,200 ft.lb/min)
3000 r.p.m.:	71,700 Nm/min (52,700 ft.lb/min)
Weight	: 14.5Kg (32lb)

Torque: Slip characteristic

i.e. Gives torque at moment of engagement and as load is accelerated.

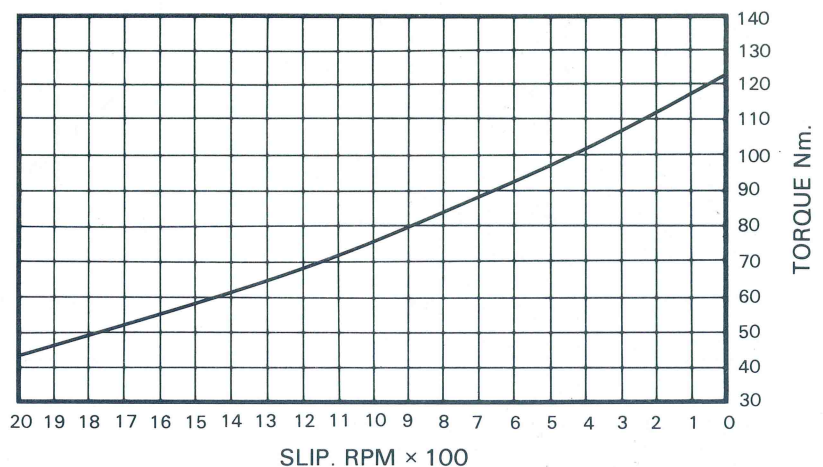

DATA SHEET
SIZE
BM800

SELF-ADJUSTING
ELECTROMAGNETIC
CLUTCHES
TYPE BM

ALL
BRITISH
COMPANY

WITH BEARING MOUNTED STATIONARY FIELD

Observe shaft parallel alignment requirements as given on Assembly and Maintenance data sheet at front of catalogue.

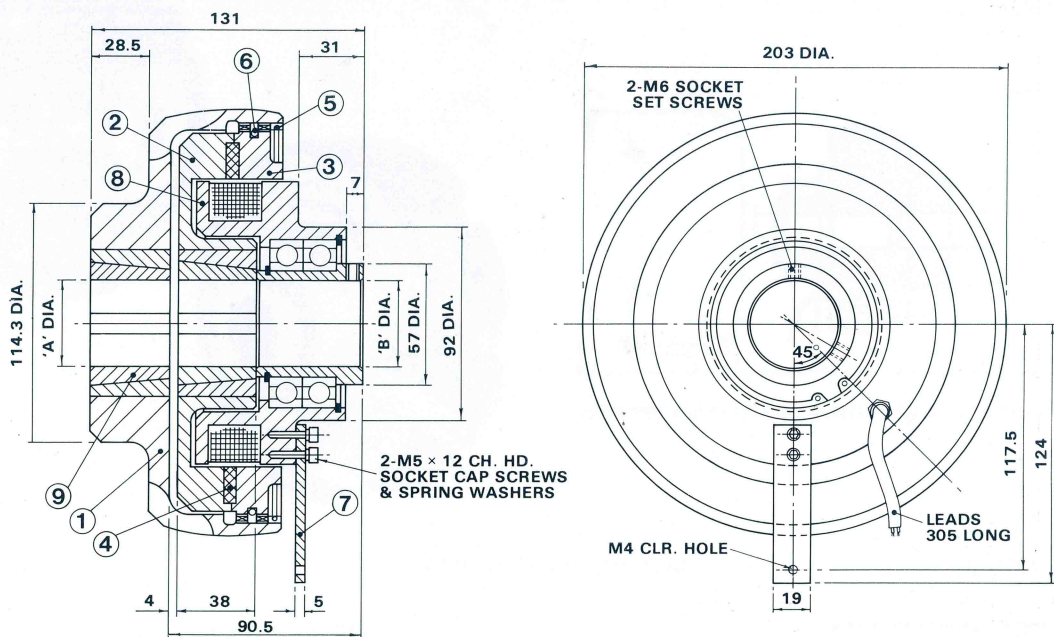

STANDARD BORES

Note : Torque arm to be fastened only to relieve coil leads from light bearing drag. Do not tighten so as to load the bearing unnecessarily.

PARTS LIST

ITEM	PART No.	TITLE	No. OFF
1	581	OUTER MEMBER	1
2	4828	INNER ROTOR	1
3	4328	DRIVE RING	1
4	4330	FRICITION RING	1
5	729	SPRING CLIP	1
6	730	CUSHION RING	1
7	3051	TORQUE ARM	1
8	3053	FIELD SPOOL ASSY.	1
9		TAPER ADAPTOR & BUSH	2

'A' INCHES	'B' INCHES	KEYWAY WIDTH INCHES
3/4	3/4	3/16 x 3/32
7/8	7/8	1/4 x 1/8
1	1	1/4 x 1/8
1 1/8	1 1/8	5/16 x 7/64
1 1/4	1 1/4	5/16 x 7/64
1 3/8	1 3/8	3/8 x 1/8
1 1/2	1 1/2	3/8 x 1/8
1 5/8	1 5/8	7/16 x 1/8
Metric Sizes (mm)		
16	16	5 x 2.3
18 19	18 19	6 x 2.8
24 25	24 25	8 x 3.3
28 30	28 30	
32 35	32 35	10 x 3.3
38	38	
40 42	40 42	12 x 1.3

CLARK ELECTRIC CLUTCH AND CONTROLS Ltd

28 Victory Park, Trident Close, Medway City Estate, Rochester, Kent, ME2 4ER
Tel.: +44 (0)1634 297408 Fax.: +44 (0)1634 739136 e-mail: sales@clarkelectric.co.uk